



# ALUMINUM CONTRACTOR BODY

## TC-504 EDGE



Racks Material:  
.125" Thk X 2" X 3"  
6061 T6 tubing

Racks can ship  
unassembled

Black T-handle latches

Double panel doors

Drop sides & tailgate  
anodized for best durability

Sizes Available  
96x120 & 96x145

96"X 145" SHOWN

PHOTO MAY SHOW OPTIONS OR CUSTOM MODIFICATIONS NOT AVAILABLE FROM TRUCKCRAFT

TRUCKCRAFT RESERVES THE RIGHT TO MAKE PRODUCT MODIFICATIONS WITHOUT PRIOR NOTIFICATION

- Constructed of 100% Aluminum—Floor and 6" longsills - 6061 T6 alloy extrusion
- Sizes avail - 96" X 120" and 96" X 145"
- Weight—145" = 1,092lb; 120" = 915lb
- 16" high anodized aluminum tailgate and sides
- Floor width between compartments = 57"; 200 lb/SF load rating
- Four recessed tie-downs in deck
- Storage compartments volume: 96"X120" = 27 Cu ft ; 96"X145 = 36 Cu ft
- Compartments are made of .090 thk, aluminum sheet
- Double panel compartment doors use twist-lock T-handles for firm seal
- Compartment latches are black polymer T-handle
- Door seals - bulb-type "D" seal
- Storage Racks have swing away rear bar, 2 removable center cross bars
- Rack weight capacity—750#
- Stainless steel compartment hinges and body hardware
- **Opts:** Underbody boxes, Fender kit, Rear step bumper, Pintle plate w/bumper
- Mounts to truck frame with optional TC-500 mounting kit
- LED marker lights with harness included
- Two year factory warranty

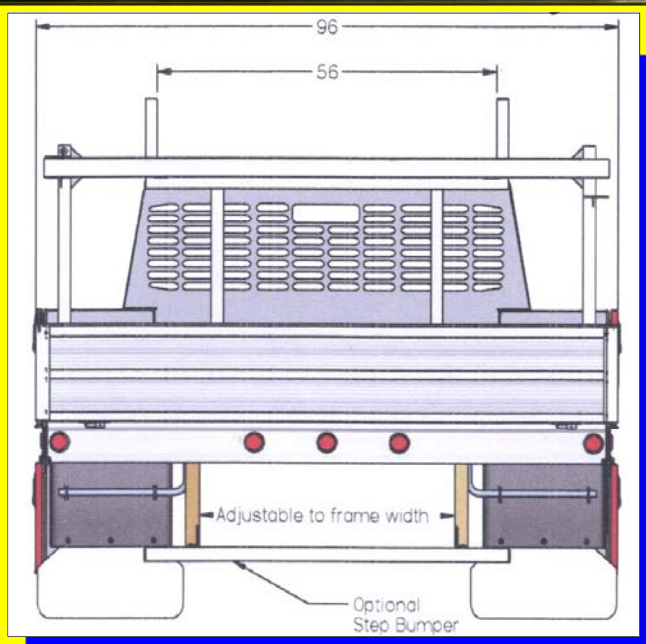

TC-504 CONTRACTOR EDGE 7/1/13